

## MODEL PA-160 HD12

### PA-160 HD12 SPECIFICATIONS

WEIGHT CAPACITY	: 16,000 Pounds
CENTER OF GRAVITY	: 12 Inches
TABLE SIZE	: 60" x 60"
ROTATION SPEED	: .015 to .6 R.P.M.
ROTATION TORQUE	: 192,000 Inch Pounds
MOTOR	: 3 Horsepower DC
TILT RANGE	: 0° to 135°
TILT TORQUE	: 344,000 Inch Pounds
ADJUSTABLE BASE	: 49-3/4" to 73-3/4" Table
VOLTAGE	: 230/460V/60/3 AC

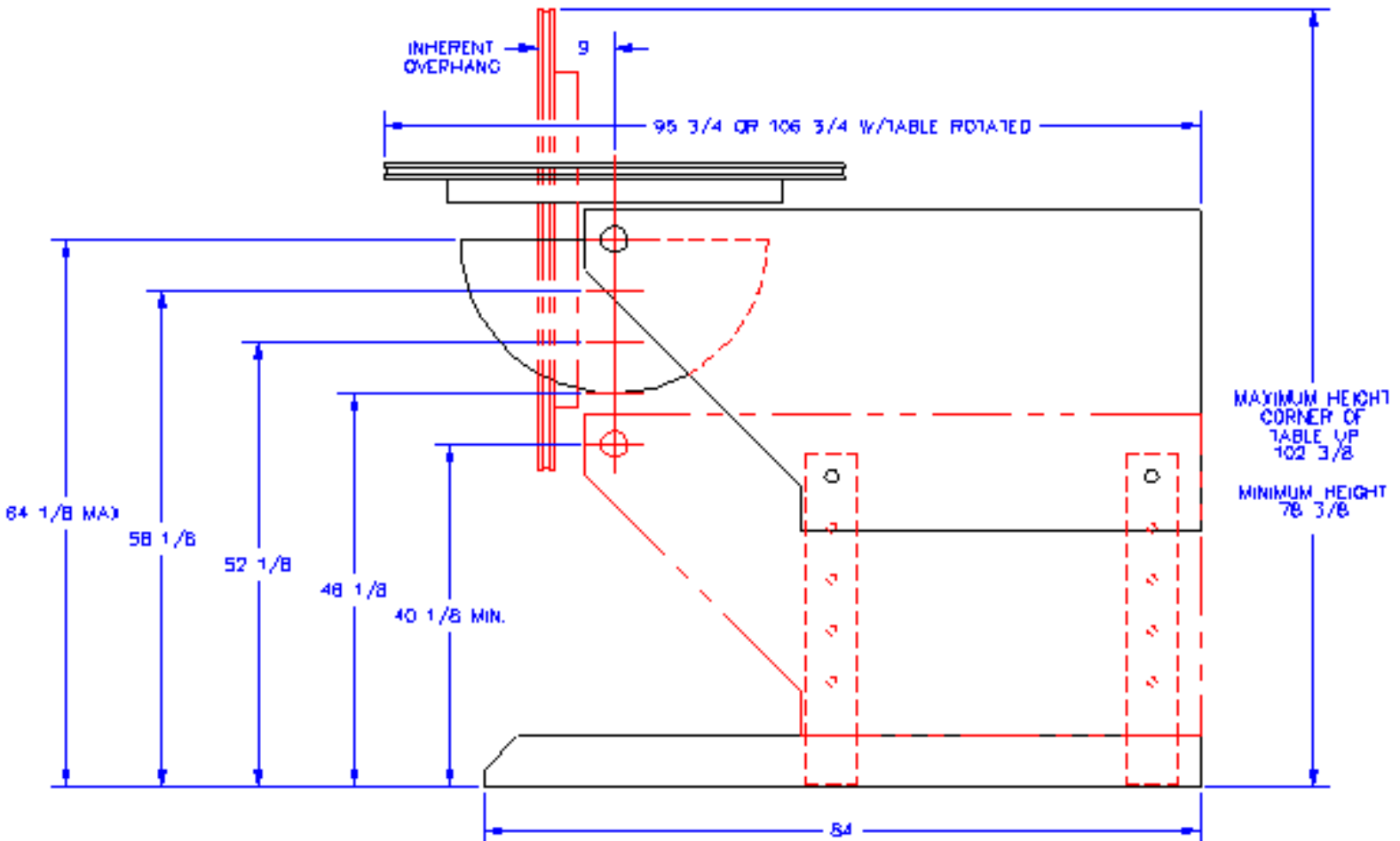
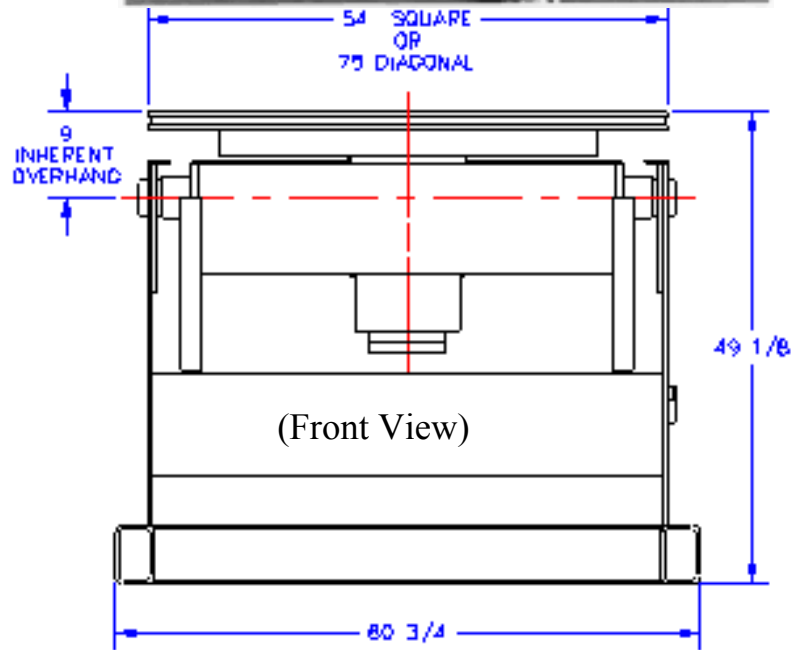

## POSITIONER LOAD CAPACITY TABLE

MODEL	Positioner Rating (lb@C.G.)	Rotat. Torque (lb-in)	Tilt Torque (lb-in)	Inh. Ovr. (in)	Load Center of Gravity (Inches away from Positioner Table)										
					4	6	12	18	24	30	36	42	48	54	60
PA-2MT	250@2.5"	625	1,450	3.31	200	155	95	68	53	44	37	-	-	-	-
PA-5MT	500@4.0"	2,000	4,000	3.81	500	400	250	180	140	115	100	85	75	69	63
PA-15 HD4	1,500@4.0"	6,000	18,100	4.25	1,500	1,500	1,110	810	640	525	450	390	340	310	280
PA-10 HD12	1,000@12"	12,000	15,900	5.25	1,000	1,000	1,000	680	540	450	385	335	300	265	245
PA-20 HD6	2,000@6.0"	12,000	15,900	5.25	1,700	1,410	920	680	540	450	385	335	300	265	245
PA-25 HD6	2,500@6.0"	15,000	23,850	5.56	2,500	2,060	1,355	1,010	805	670	575	500	445	400	365
PA-30 HD6	3,000@6.0"	18,000	29,735	6.00	3,000	2,475	1,650	1,240	990	825	705	620	550	495	450
PA-30 HD12	3,000@12"	36,000	75,250	7.00	3,000	3,000	3,000	3,000	2,425	2,035	1,750	1,535	1,365	1,235	1,120
PA-45 HD12	4,500@12"	54,000	91,900	7.00	4,500	4,500	4,500	3,675	2,965	2,485	2,135	1,875	1,670	1,505	1,370
PA-60 HD12	6,000@12"	72,000	124,500	8.75	6,000	6,000	6,000	4,655	3,800	3,210	2,780	2,450	2,195	1,985	1,810
PA-100 HD12	10,000@12"	120,000	163,300	9.00	10,000	10,000	7,775	6,045	4,945	4,185	3,630	3,200	2,865	2,590	2,365
PA-160 HD12	16,000@12"	192,000	344,000	9.50	16,000	16,000	16,000	12,500	10,265	8,700	7,560	6,680	5,980	5,415	4,950
PA-240 HD12	24,000@12"	288,000	510,000	9.25	24,000	24,000	24,000	18,715	15,340	12,995	11,270	9,950	8,900	8,065	7,365
PA-300 HD12	30,000@12"	360,000	720,000	12.00	30,000	30,000	30,000	24,000	20,000	17,140	15,000	13,330	12,000	10,900	10,000
PA-400 HD12	40,000@12"	480,000	960,000	12.00	40,000	40,000	40,000	32,000	26,665	22,855	20,000	17,775	16,000	14,545	13,330
PA-500 HD12	50,000@12"	600,000	1,200,000	12.00	50,000	50,000	50,000	40,000	33,330	28,570	25,000	22,220	20,000	18,180	16,665

## Selecting the Proper Positioner



### Positioner Rotating Capacity

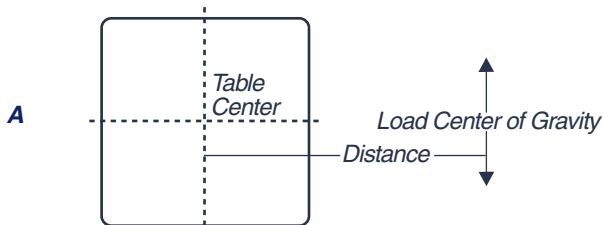

$$\text{Load (lb)} \times \text{Distance (inches)} = \text{Rotational Torque Rating (lb-inches)}$$

### Positioner Tilt Capacity

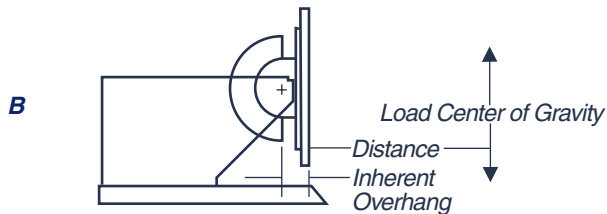

$$\text{Load (lb)} \times (\text{Distance (inches)} + \text{Inherent Overhang (inches)}) = \text{Tilt Torque Rating (lb-inches)}$$

1. Determine the total weight you will be positioning including fixtures.
2. Calculate the center of gravity of the work by determining:
  - A. Distance from rotational center
  - B. Distance from face of table
3. Using the distance found in step 2A, calculate the rotational torque required. (Use the formula from fig. A)
4. Using the distance found in step 2B, calculate the tilt torque required. (Use the formula from fig. B)
5. Compare the required rotational and tilt torque with the chart on page 38. Select a positioner with a load capacity equal to, or greater than your requirements.