

PRO*WELD

INTERNATIONAL

CD-312



OPERATION/MAINTENANCE MANUAL

TABLE OF CONTENTS

1.0	INTRODUCTION	1
2.0	WARRANTY	1
3.0	UNPACKING YOUR UNIT	1
4.0	SUGGESTED SAFETY PRECAUTIONS	1
5.0	GENERAL DESCRIPTION	2
6.0	THE CD WELDING PROCESS	2
7.0	POWER REQUIREMENTS	3
8.0	SYSTEM SPECIFICATIONS	3
9.0	WELDING SYSTEM HOOK-UP	4
9.1	Straight Polarity	4
9.2	Reverse Polarity	5
9.3	Cuphead Pin	6
10.0	SYSTEM OPERATION	7
11.0	GUN SET-UP	9
11.1	Standard	9
11.2	Installing or Changing Collets or Chucks	10
11.3	For Weld Pins with Collet Protector	10
11.4	Template Adapter	11
11.5	Collet Protector with Blunt Leg	11
11.6	Parts List LD CD Handgun	14
12.0	WELDABLE MATERIAL COMBINATIONS	15
13.0	CAUSES OF POOR OR ERRATIC WELDS	16
14.0	TROUBLE SHOOTING POOR WELDS	16
15.0	ROUTINE WELDER MAINTENANCE	17
16.0	ASSEMBLY –CD-312 CONTROLLER	18,19,20
16.1	PC Board Assembly Drawing	21
17.0	TROUBLE SHOOTING – ELECTRICAL	22
18.0	CHECK LIST CD-312 SYSTEM P.N. 100-0108	24
19.0	CHECK LIST CD-312 SYSTEM P.N. 100-0109	24

LIST OF FIGURES

1	CD CONTACT PROCESS	2
2	STRAIGHT POLARITY HOOK-UP	4
3	REVERSE POLARITY HOOK-UP	5
4	CUPHEAD PIN HOOK-UP	6
5	FRONT PANEL LAYOUT	7
6	STANDARD GUN SETUP	9
7	COLLET PROTECTOR SETUP	10
8	TEMPLATE ADAPTER GUN SETUP	11
9	COLLET PROTECTOR/BLUNT LEG SETUP	11
10	LIGHT DUTY CD GUN	13
11	HOT WELD	16
12	COLD WELD	16
13	ARC BLOW	17
14	WELD WITHOUT FOOTPIECE	17
15	GOOD WELD	17
16	PARTS LIST	18
17	PARTS LIST (continued)	19
18	PARTS LIST (continued)	20
19	PC BOARD	21

SECTION 1 – SAFETY PRECAUTIONS - READ BEFORE USING

1-1. Symbol Usage



Means Warning! Watch Out! There are possible hazards with this procedure! The possible hazards are shown in the adjoining symbols.

▲ Marks a special safety message.

☞ Means "Note"; not safety related.



This group of symbols means Warning! Watch Out! possible ELECTRIC SHOCK, MOVING PARTS, and HOT PARTS hazards. Consult symbols and related instructions below for necessary actions to avoid the hazards.

1-2. Arc Welding Hazards

▲ The symbols shown below are used throughout this manual to call attention to and identify possible hazards. When you see the symbol, watch out, and follow the related instructions to avoid the hazard. The safety information given below is only a summary of the more complete safety information found in the Safety Standards listed in Section NO TAG. Read and follow all Safety Standards.

▲ Only qualified persons should install, operate, maintain, and repair this unit.

▲ During operation, keep everybody, especially children, away.



ELECTRIC SHOCK can kill.

Touching live electrical parts can cause fatal shocks or severe burns. The electrode and work circuit is electrically live whenever the output is on. The input power circuit and machine internal circuits are also live when power is on. In semiautomatic or automatic wire welding, the wire, wire reel, drive roll housing, and all metal parts touching the welding wire are electrically live. Incorrectly installed or improperly grounded equipment is a hazard.

- Do not touch live electrical parts.
- Wear dry, hole-free insulating gloves and body protection.
- Insulate yourself from work and ground using dry insulating mats or covers big enough to prevent any physical contact with the work or ground.
- Do not use AC output in damp areas, if movement is confined, or if there is a danger of falling.
- Use AC output ONLY if required for the welding process.
- If AC output is required, use remote output control if present on unit.
- Disconnect input power or stop engine before installing or servicing this equipment. Lockout/tagout input power according to OSHA 29 CFR 1910.147 (see Safety Standards).
- Properly install and ground this equipment according to its Owner's Manual and national, state, and local codes.
- Always verify the supply ground – check and be sure that input power cord ground wire is properly connected to ground terminal in disconnect box or that cord plug is connected to a properly grounded receptacle outlet.
- When making input connections, attach proper grounding conductor first – double-check connections.
- Frequently inspect input power cord for damage or bare wiring – replace cord immediately if damaged – bare wiring can kill.
- Turn off all equipment when not in use.
- Do not use worn, damaged, undersized, or poorly spliced cables.
- Do not drape cables over your body.

- If earth grounding of the workpiece is required, ground it directly with a separate cable – do not use work clamp or work cable.
- Do not touch electrode if you are in contact with the work, ground, or another electrode from a different machine.
- Use only well-maintained equipment. Repair or replace damaged parts at once. Maintain unit according to manual.
- Wear a safety harness if working above floor level.
- Keep all panels and covers securely in place.
- Clamp work cable with good metal-to-metal contact to workpiece or worktable as near the weld as practical.
- Insulate work clamp when not connected to workpiece to prevent contact with any metal object.
- Do not connect more than one electrode or work cable to any single weld output terminal.

SIGNIFICANT DC VOLTAGE exists after removal of input power on inverters.

- Turn Off inverter, disconnect input power, and discharge input capacitors according to instructions in Maintenance Section before touching any parts.



FUMES AND GASES can be hazardous.

Welding produces fumes and gases. Breathing these fumes and gases can be hazardous to your health.

- Keep your head out of the fumes. Do not breathe the fumes.
- If inside, ventilate the area and/or use exhaust at the arc to remove welding fumes and gases.
- If ventilation is poor, use an approved air-supplied respirator.
- Read the Material Safety Data Sheets (MSDSs) and the manufacturer's instructions for metals, consumables, coatings, cleaners, and degreasers.
- Work in a confined space only if it is well ventilated, or while wearing an air-supplied respirator. Always have a trained watch-person nearby. Welding fumes and gases can displace air and lower the oxygen level causing injury or death. Be sure the breathing air is safe.
- Do not weld in locations near degreasing, cleaning, or spraying operations. The heat and rays of the arc can react with vapors to form highly toxic and irritating gases.
- Do not weld on coated metals, such as galvanized, lead, or cadmium plated steel, unless the coating is removed from the weld area, the area is well ventilated, and if necessary, while wearing an air-supplied respirator. The coatings and any metals containing these elements can give off toxic fumes if welded.



ARC RAYS can burn eyes and skin.

Arc rays from the welding process produce intense visible and invisible (ultraviolet and infrared) rays that can burn eyes and skin. Sparks fly off from the weld.

- Wear a welding helmet fitted with a proper shade of filter to protect your face and eyes when welding or watching (see ANSI Z49.1 and Z87.1 listed in Safety Standards).
- Wear approved safety glasses with side shields under your helmet.
- Use protective screens or barriers to protect others from flash and glare; warn others not to watch the arc.
- Wear protective clothing made from durable, flame-resistant material (leather and wool) and foot protection.



WELDING can cause fire or explosion.

Welding on closed containers, such as tanks, drums, or pipes, can cause them to blow up. Sparks can fly off from the welding arc. The flying sparks, hot workpiece, and hot equipment can cause fires and burns. Accidental contact of electrode to metal objects can cause sparks, explosion, overheating, or fire. Check and be sure the area is safe before doing any welding.

- Protect yourself and others from flying sparks and hot metal.
- Do not weld where flying sparks can strike flammable material.
- Remove all flammables within 35 ft (10.7 m) of the welding arc. If this is not possible, tightly cover them with approved covers.
- Be alert that welding sparks and hot materials from welding can easily go through small cracks and openings to adjacent areas.
- Watch for fire, and keep a fire extinguisher nearby.
- Be aware that welding on a ceiling, floor, bulkhead, or partition can cause fire on the hidden side.
- Do not weld on closed containers such as tanks, drums, or pipes, unless they are properly prepared according to AWS F4.1 (see Safety Standards).
- Connect work cable to the work as close to the welding area as practical to prevent welding current from traveling long, possibly unknown paths and causing electric shock and fire hazards.
- Do not use welder to thaw frozen pipes.
- Remove stick electrode from holder or cut off welding wire at contact tip when not in use.
- Wear oil-free protective garments such as leather gloves, heavy shirt, cuffless trousers, high shoes, and a cap.
- Remove any combustibles, such as a butane lighter or matches, from your person before doing any welding.

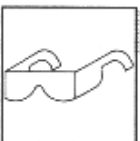

FLYING METAL can injure eyes.

- Welding, chipping, wire brushing, and grinding cause sparks and flying metal. As welds cool, they can throw off slag.
- Wear approved safety glasses with side shields even under your welding helmet.



BUILDUP OF GAS can injure or kill.

- Shut off shielding gas supply when not in use.
- Always ventilate confined spaces or use approved air-supplied respirator.



HOT PARTS can cause severe burns.

- Do not touch hot parts bare handed.
- Allow cooling period before working on gun or torch.



MAGNETIC FIELDS can affect pacemakers.

- Pacemaker wearers keep away.
- Wearers should consult their doctor before going near arc welding, gouging, or spot welding operations.



NOISE can damage hearing.

Noise from some processes or equipment can damage hearing.

- Wear approved ear protection if noise level is high.



CYLINDERS can explode if damaged.

Shielding gas cylinders contain gas under high pressure. If damaged, a cylinder can explode. Since gas cylinders are normally part of the welding process, be sure to treat them carefully.

- Protect compressed gas cylinders from excessive heat, mechanical shocks, slag, open flames, sparks, and arcs.
- Install cylinders in an upright position by securing to a stationary support or cylinder rack to prevent falling or tipping.
- Keep cylinders away from any welding or other electrical circuits.
- Never drape a welding torch over a gas cylinder.
- Never allow a welding electrode to touch any cylinder.
- Never weld on a pressurized cylinder – explosion will result.
- Use only correct shielding gas cylinders, regulators, hoses, and fittings designed for the specific application; maintain them and associated parts in good condition.
- Turn face away from valve outlet when opening cylinder valve.
- Keep protective cap in place over valve except when cylinder is in use or connected for use.
- Read and follow instructions on compressed gas cylinders, associated equipment, and CGA publication P-1 listed in Safety Standards.



ARC RAYS can burn eyes and skin.

Arc rays from the welding process produce intense visible and invisible (ultraviolet and infrared) rays that can burn eyes and skin. Sparks fly off from the weld.

- Wear a welding helmet fitted with a proper shade of filter to protect your face and eyes when welding or watching (see ANSI Z49.1 and Z87.1 listed in Safety Standards).
- Wear approved safety glasses with side shields under your helmet.
- Use protective screens or barriers to protect others from flash and glare; warn others not to watch the arc.
- Wear protective clothing made from durable, flame-resistant material (leather and wool) and foot protection.



WELDING can cause fire or explosion.

Welding on closed containers, such as tanks, drums, or pipes, can cause them to blow up. Sparks can fly off from the welding arc. The flying sparks, hot workpiece, and hot equipment can cause fires and burns. Accidental contact of electrode to metal objects can cause sparks, explosion, overheating, or fire. Check and be sure the area is safe before doing any welding.

- Protect yourself and others from flying sparks and hot metal.
- Do not weld where flying sparks can strike flammable material.
- Remove all flammables within 35 ft (10.7 m) of the welding arc. If this is not possible, tightly cover them with approved covers.
- Be alert that welding sparks and hot materials from welding can easily go through small cracks and openings to adjacent areas.
- Watch for fire, and keep a fire extinguisher nearby.
- Be aware that welding on a ceiling, floor, bulkhead, or partition can cause fire on the hidden side.
- Do not weld on closed containers such as tanks, drums, or pipes, unless they are properly prepared according to AWS F4.1 (see Safety Standards).
- Connect work cable to the work as close to the welding area as practical to prevent welding current from traveling long, possibly unknown paths and causing electric shock and fire hazards.
- Do not use welder to thaw frozen pipes.
- Remove stick electrode from holder or cut off welding wire at contact tip when not in use.
- Wear oil-free protective garments such as leather gloves, heavy shirt, cuffless trousers, high shoes, and a cap.
- Remove any combustibles, such as a butane lighter or matches, from your person before doing any welding.



FLYING METAL can injure eyes.

- Welding, chipping, wire brushing, and grinding cause sparks and flying metal. As welds cool, they can throw off slag.
- Wear approved safety glasses with side shields even under your welding helmet.



BUILDUP OF GAS can injure or kill.

- Shut off shielding gas supply when not in use.
- Always ventilate confined spaces or use approved air-supplied respirator.



HOT PARTS can cause severe burns.

- Do not touch hot parts bare handed.
- Allow cooling period before working on gun or torch.



MAGNETIC FIELDS can affect pacemakers.

- Pacemaker wearers keep away.
- Wearers should consult their doctor before going near arc welding, gouging, or spot welding operations.



NOISE can damage hearing.

Noise from some processes or equipment can damage hearing.

- Wear approved ear protection if noise level is high.



CYLINDERS can explode if damaged.

Shielding gas cylinders contain gas under high pressure. If damaged, a cylinder can explode. Since gas cylinders are normally part of the welding process, be sure to treat them carefully.

- Protect compressed gas cylinders from excessive heat, mechanical shocks, slag, open flames, sparks, and arcs.
- Install cylinders in an upright position by securing to a stationary support or cylinder rack to prevent falling or tipping.
- Keep cylinders away from any welding or other electrical circuits.
- Never drape a welding torch over a gas cylinder.
- Never allow a welding electrode to touch any cylinder.
- Never weld on a pressurized cylinder - explosion will result.
- Use only correct shielding gas cylinders, regulators, hoses, and fittings designed for the specific application; maintain them and associated parts in good condition.
- Turn face away from valve outlet when opening cylinder valve.
- Keep protective cap in place over valve except when cylinder is in use or connected for use.
- Read and follow instructions on compressed gas cylinders, associated equipment, and CGA publication P-1 listed in Safety Standards.

1-5. EMF Information

Considerations About Welding And The Effects Of Low Frequency Electric And Magnetic Fields

Welding current, as it flows through welding cables, will cause electromagnetic fields. There has been and still is some concern about such fields. However, after examining more than 500 studies spanning 17 years of research, a special blue ribbon committee of the National Research Council concluded that: "The body of evidence, in the committee's judgment, has not demonstrated that exposure to power-frequency electric and magnetic fields is a human-health hazard." However, studies are still going forth and evidence continues to be examined. Until the final conclusions of the research are reached, you may wish to minimize your exposure to electromagnetic fields when welding or cutting.

To reduce magnetic fields in the workplace, use the following procedures:

1. Keep cables close together by twisting or taping them.
2. Arrange cables to one side and away from the operator.
3. Do not coil or drape cables around your body.
4. Keep welding power source and cables as far away from operator as practical.
5. Connect work clamp to workpiece as close to the weld as possible.

About Pacemakers:

Pacemaker wearers consult your doctor first. If cleared by your doctor, then following the above procedures is recommended.

1.0 INTRODUCTION

Your new stud welding equipment is carefully constructed of the finest components and materials available. Used properly, this equipment will give you years of profitable, efficient service.

The system incorporates the latest in engineering advances, for completely reliable end welding of mild steel, stainless steel, aluminum and lead free copper and brass fasteners.

A careful study of this manual will enable you to understand how the welder operates to insure proper performance under all operating conditions.

2.0 WARRANTY

The electrical and mechanical components of the stud welder are thoroughly performance inspected prior to assembly in the welder. The assembled welder is completely performance checked. The welder is delivered to you in functional electro-mechanical condition.

All parts used in the assembly of the welder and its accessories are fully warranted for a period of ninety (90) days from the date of delivery. In addition, the welding capacitors are warranted for a period of one hundred twenty (120) days from the date of delivery.

Under the warranty, the manufacturer reserves the right to repair or replace, at their option, defective parts which fail during the guarantee period. Notice of any claim for warranty repair or replacement must be furnished to the manufacturer by the purchaser within ten (10) days after the defect is first discovered. The manufacturer does not assume any liability for paying shipping cost or any labor or materials furnished where such cost are not expressly authorized in writing.

The manufacturer does not warrant any parts or accessories against failures resulting from misuse, abuse, improper installation, maladjustment, or use not in accordance with the operating instructions furnished by the manufacturer. The warranty is valid only when studs are purchased from sources approved by the manufacturer or are of identical speci-

3.0 UNPACKING YOUR UNIT

Upon receipt of your unit, place it as close as possible to the point of installation before unpacking it. Do not operate the unit from an extension power cord if possible. Once the unit is unpacked it is recommended that you inspect it for any physical damage.

Your unit has been completely assembled and inspected at the factory. Upon receipt, the unit must be hooked up to the recommended incoming power before welding. We recommend that you check that you have received all the items listed on the shipping check list. (see SECTION 18 or 19)

Place the unit in a large enough area to provide adequate ventilation. Do not restrict the air flow through the side louvers. Do not allow water to enter the control housing.

4.0 SUGGESTED SAFETY PRECAUTIONS

In any welding operation, it is the responsibility of the welder to observe certain safety rules to insure his personal safety and to protect those working near him.

Reference is directed, without endorsement or recommendation, to ANSI Z49.1, Safety in Welding and Cutting, and to AWG Publication A6,1-66, Recommended Safety Practices for Gas-Shield Arc Welding.

1. Always treat electricity with respect. Under open circuit conditions, the welding machine output voltage may be dangerous.
2. Don't work on live circuits or conductors. Disconnect the main power line before checking the machine or performing any maintenance operations.
3. Be sure the welding machine cabinet is properly grounded to a good electrical ground.
4. Don't stand in water or on a damp floor while welding or weld in the rain. Avoid wearing wet sweaty cloths when welding.

5. Don't operate with worn or poorly connected cables. Don't operate weld gun with loose cable connections. Inspect all cables frequently for insulation failures, exposed wires, loose connections, and repair as needed.
6. Don't overload welding cables or continue to operate with hot cables.
7. Don't weld near flammable materials or liquids, in or near atmospheres, or on ducts carrying explosive gases.
8. Don't weld on containers which have held combustible or flammable materials, or on materials which give off flammable or toxic vapors when heated, without proper cleaning, purging, or inerting.
9. Be sure to provide for proper ventilation when welding in confined spaces.
10. Never look at the electric arc without wearing protective eye shields.
11. Always use the proper protective clothing, gloves, ect.
12. Never strike an arc when near a bystander who is unaware of the dangers of ultraviolet light on their eyes.

5.0 GENERAL DESCRIPTION

CD-312 HEAVY DUTY PORTABLE CD STUD/PIN WELDER

The CD-312 portable CD welder is a self contained heavy duty capacitor discharge power supply capable of welding up to 5/16" flanged studs in mild steel or stainless steel (3/8" in weld base diameter). It can weld up to 1/4 flanged studs (5/16" weld base diameter) in aluminum or brass.

The CD-312 utilizes a solid state control board for longer life and has been designed for easy maintenance and field service. This welder uses standard

110 volt AC line voltage. The system comes complete with power cord, weld cables and gun. Just add the accessories required for the stud size to be welded. This manual should provide all the information required for you to be able to set up, weld, and maintain the CD-312 welding system.

6.0 THE CD WELDING PROCESS

Contact welding is the simplest and most common method of CD stud welding. Practically foolproof, it produces no reverse side marking in most cases and is suitable for most commercial and industrial applications.

First, the gun must be set-up with the proper accessories for the length and diameter stud you are going to weld. Refer to the CD Accessories Guide and CD Stud Welding Gun Section for information on accessories and gun set-up.

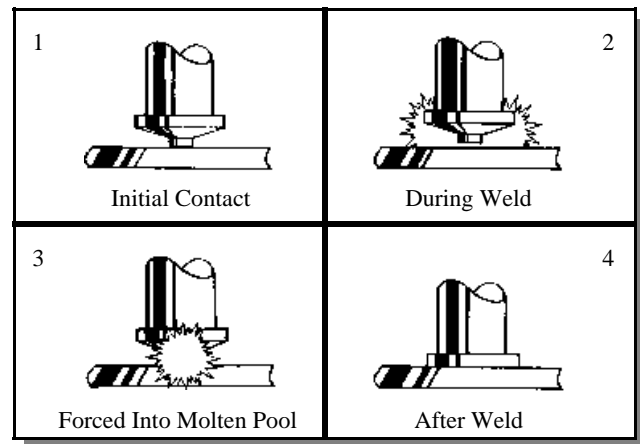

(FIGURE 1 CONTACT CD WELD)

The stud is first placed in contact with the base material (SEE FIGURE 1). Verify that the gun is held perpendicular to the work. Pulling the trigger discharges the capacitors through the stud which vaporizes the tip. The proper tip design is critical. This is what determines the length of time of the weld. An arc is briefly sustained which melts the stud base surface and the work surface directly underneath the stud. The spring pressure in the gun then forces the stud into the molten pool, completing the weld in approximately six milliseconds.

This technique, when equipment is set up properly, is simple and easily mastered. The same power supply is capable of welding many different sizes and materials of fasteners. If you require assistance in selecting the proper accessories, contact our customer service department or your field representative.

7.0 POWER REQUIREMENTS

110 VOLT OPERATION

110 volt AC 60 H: 25 amp service
 Internal : 20 amp;
 circuit breaker (P/N: 104-0021)
 Integral 9 foot power cord

IF EXTENSION REQUIRED

Cable Length	110 Volt
12'	#16/3
25'	#16/3
30'	#14/3
50'	#12/3

8.0 SYSTEM SPECIFICATIONS

Weight:

48 Lbs.

Size:

8 1/2" W x 10" D x 16 1/2" H
 21.6 cm W x 25.4 cm D x 42 cm H

Chassis:

16 Ga. Steel (Painted International Orange)

Panel Controls:

Power
 Voltage Control

Weldable Materials:

Steel, Stainless steel, Aluminum, Copper,
 Brass, Zinc coated, Galvanized

Weldable Stud Diameter:

12 Ga. Through 3/8" Weld Base
 (Max W.B. Dia. For AL=5/16" {1/4" thread})

Weld Rate:

24 per minute 5/16"

Weld Voltage:

45-185 VDC

Capacitance:

88,000 uF nominal

Weld Mode:

Contact

Polarity:

Straight or Reverse

Power Required:

110 Volt AC 60 Hz 25 Amp

Internal Fusing:

20 Amp Circuit Breaker
 3AG 1 Amp 250 volt (2 on PC board)

STANDARD GUN & CABLE SPECIFICATIONS

WELD GUN-LIGHT DUTY PRECISION
 CD CONTACT

Part Number:

300-0100 B Collet Gun
 300-0101 Taper Tip Gun

Weight:

2 lbs. (not including cable)
 (lbs. (including 25 ft. #4 weld cable & 16-4
 SOW control cable)

Size:

6 1/2" x 5 3/4" x 2"

Weldable Stud Diameter:

14 Ga. Through 1/4" Flanged

Material:

High strength, impact resistant, glass fiber re-
 inforced polycarbonate

Integral Gun Cable Length:

25 feet – #4 AWG

Connectors:

Male Camlok / 2 Pin Hubbell Male

Cables

Ground Cable:

(1) #4 x 15' (P/N: 125-0100)

9.0 WELDING SYSTEM HOOK-UP

9.1 Straight Polarity (Standard Set-Up) (see Figure 2)

A. Connect ground cable connector (1A) into camlok (1). The camlok should be connected into the receptacle marked GROUND. Twist until it locks. Attach “C” clamp (2) to the workpiece (5) (CLEANED AREA).

B. Connect the gun control cable (3A) into the female receptacle (3).

C. Connect the gun weld cable (4A) into the receptacle marked GUN (4). Twist clockwise until it locks.

D. Connect AC power cable to AC outlet.

NOTE:

The gun welding and control cables must be laid out in a straight line. Poor weld quality may result if welding cables are coiled.

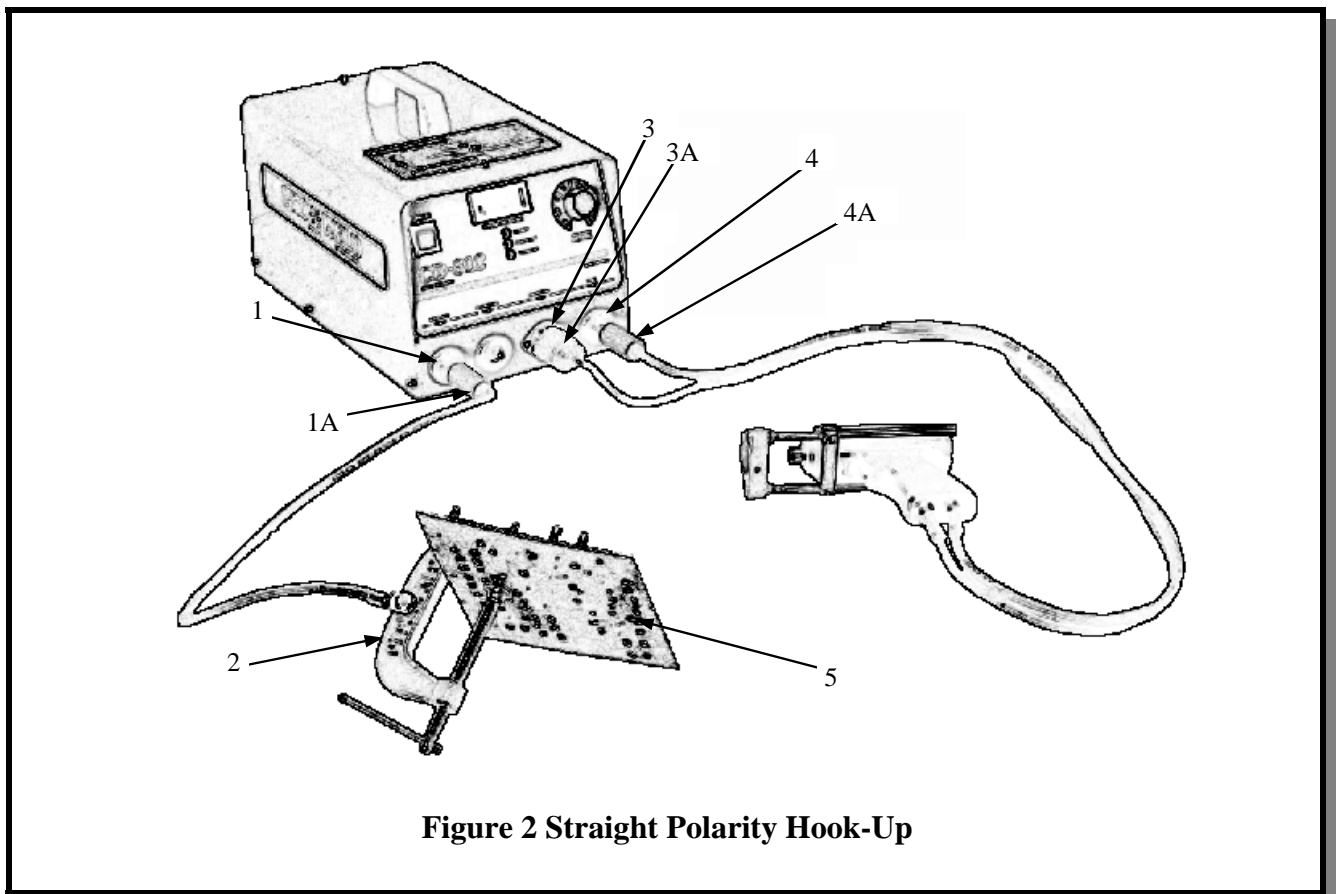

9.2 Reverse Polarity (Recommended for brass or galvanized) (see Figure 3)

A. Connect ground cable connector (1A) into camlok (4). The camlok should be connected into the receptacle marked GUN. Twist until it locks. Attach “C” clamp (2) to the workpiece (5) (CLEANED AREA).

B. Connect the gun control cable (3A) into the female receptacle (3).

C. Connect the gun weld cable (4A) into the receptacle marked GROUND (1). Twist clockwise until it locks.

D. Connect AC power cable to AC outlet.

NOTE:

The gun welding and control cables must be laid out in a straight line. Poor weld quality may result if welding cables are coiled.

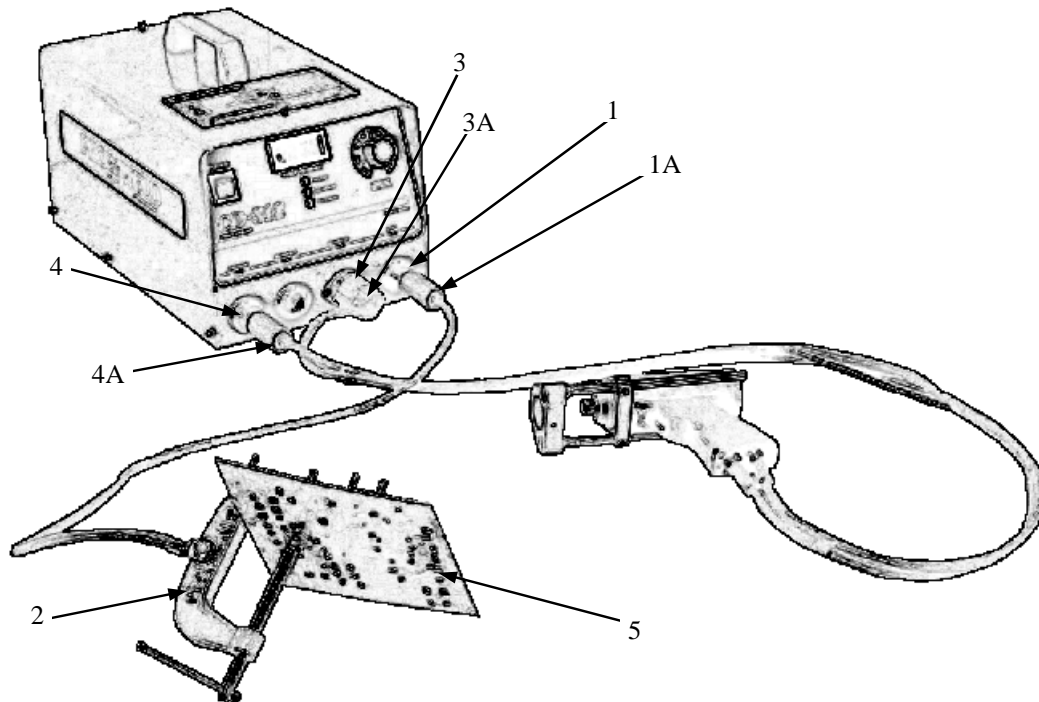

Figure 3 Reverse Polarity Hook-Up

9.3 Cuphead and Power Point pin hook-up (see Figure 4)

A. Connect ground cable connector (1A) into camlok (1). The camlok should be connected into the receptacle marked CUPHEAD. Twist until it locks. Attach “C” clamp (2) to the workpiece (5) (CLEANED AREA).

B. Connect the gun control cable (3A) into the female receptacle (3).

C. Connect the gun weld cable (4A) into the receptacle marked GUN (4). Twist clockwise until it locks.

D. Connect AC power cable to AC outlet.

NOTE:

The gun welding and control cables must be laid out in a straight line. Poor weld quality may result if welding cables are coiled.

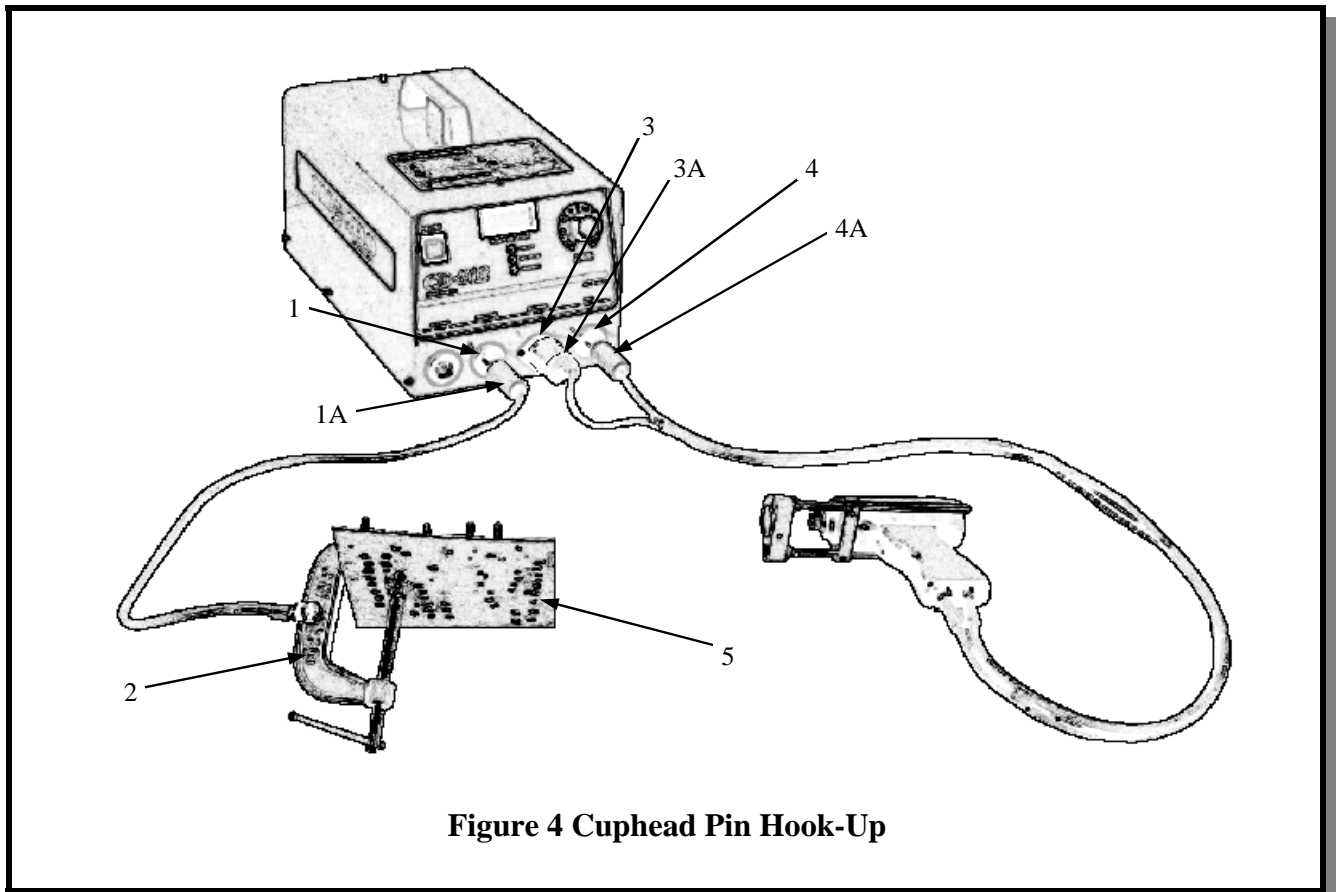

Figure 4 Cuphead Pin Hook-Up

10.0 SYSTEM OPERATION

(see Figure 4)

1. The CD-312 is designed for simple, yet precise operation.
2. It has an “ON-OFF” toggle switch/indicator light (1) and a variable voltage control dial (2), a ready indicator light (3), a contact light (4) and a trigger light (5) on the front panel.
3. Before turning the unit “ON”, the voltage control knob (2) should be turned counter-clockwise to the lowest setting.
4. With all cables connected, turn the unit on by putting the rocker switch (1) in the “ON” position. The integral indicator light (1) will turn on.
5. When the capacitors reach the charge voltage setting, the ready light (4) will turn on.

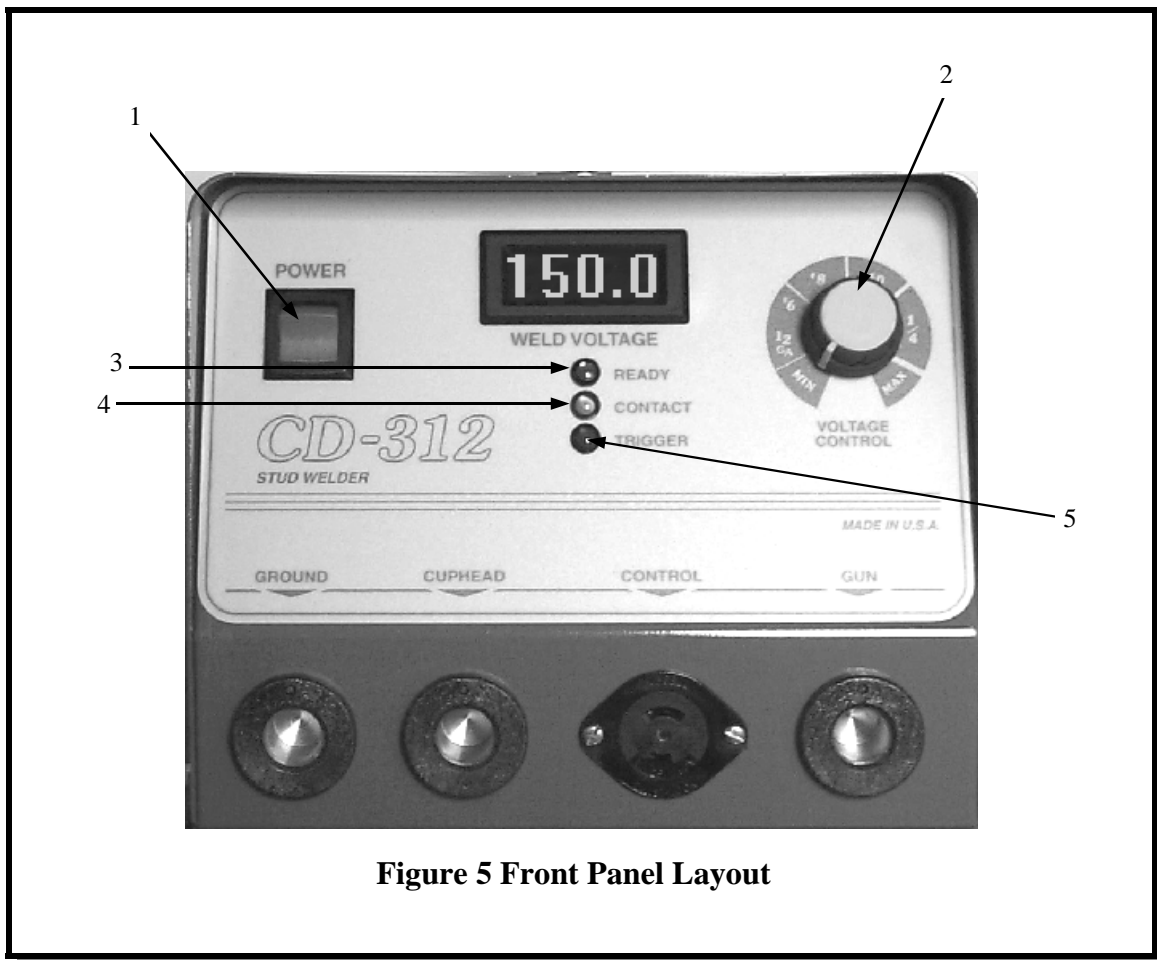

Figure 5 Front Panel Layout

Setting the Weld Voltage/Capacitance

Slowly turn the voltage control knob clockwise to increase the weld voltage until the indicator knob is pointing at the appropriate number for the particular stud size that you are welding. (See the set up information chart).

NOTE:

Once the voltage control knob is set to a higher setting, turning it counter-clockwise will NOT reduce the voltage on the capacitor bank, until the toggle switch (1) is turned "OFF" (for approximately 10 seconds).

The settings are marked with the voltages corresponding to various stud sizes. The approximate voltages for each stud size is as follows:

45 – 60 VDC	Min.
65 – 95 VDC	12 ga.
95 – 120 VDC	#8
120 – 145 VDC	#10
145 – 180 VDC	1/4"
180 – 185VDC	MAX.

The voltage charge on the capacitor bank is read on the digital panel meter. The ready light indicates when the capacitors are charged and a stud may be welded.

Contact Light

The contact light indicates there is an acceptable electrical connection between the stud and ground. This light will turn on when the stud is placed in contact with the ground.

Trigger Light

The trigger light indicates there is a complete circuit to the unit through the gun control cable and switch. This light will turn on when the gun trigger is pressed.

11.0 GUN SET-UP

11.1 STANDARD (see Figure 5)

The standard gun set-up is used for welding the majority of applications. It consists of the standard adjustable face plate, two legs, a foot, B-collet, stop, and spring for your specific stud size.

A step-by-step explanation of the correct way to set-up and operate the standard CD gun.

To prepare for stud welding, it is necessary to have the proper accessories for the stud to be welded. Those required are the legs, footpiece, spring, collet, and appropriate screws and washers. A 3/32" and a 5/32" hex wrench are the only tools needed for the adjustment of the gun.

For CD welding, the stud normally should be engaged for all but 1/4" of its length, whenever possible. Selecting the proper stop will accomplish this for you. The objective of the collet is to maintain a firm grip on the fastener to assure correct alignment and a good electrical connection, yet allow for ease of loading.

Once the selection of the correct accessory is made, assembly may begin. The footpiece is mounted on the legs using 10-32 x 3/4" socket head cap screws, inserted through the holes at the base of the footpiece. These holes are recessed so that the head of the screws will not protrude.

After assembling the legs and footpiece, insert the collet and stop into the open end of the gun shaft. Secure the collet in place with two set screws on the shaft. Locate the legs, with footpiece attached, in the

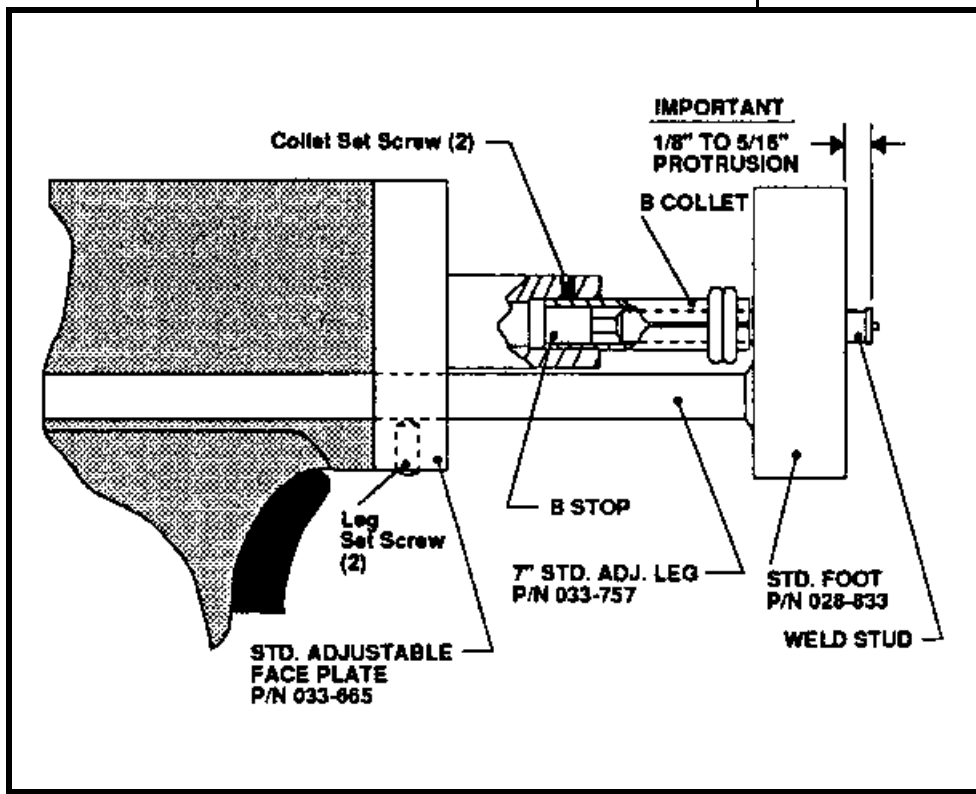

Figure 6 Standard Gun Setup

holes provided in the gun faceplate. (It may be necessary to back off the socket screw in the faceplate to allow the legs to enter the hole). Center the opening of the footpiece around the weld end of the fastener. Tighten the footpiece in position at this time. Adjustment for the plunge which is the distance the stud protrudes beyond the end of the footpiece can now be made. This is done by loosening the two 10-32 x 1/4" set screws at the bottom of the faceplate using the 3/32" Allen wrench. Then sliding the legs for proper adjustment. Refer to the set-up chart for correct plunge distance (from 1/8" to 5/16").

NOTE:

Correct set-up on all CD units is 1/8"- 5/16" plunge. This must be assured for proper weld results in all cases.

The gun is now ready to weld. Select the proper setting for the size stud to be welded. Voltage is determined by the weld base diameter. Be sure your power source is set for the proper polarity: straight for steel, reverse for galvanized.

11.2 INSTALLING OR CHANGING COLLETS OR CHUCKS

(The terms collet or chuck are different names for the same device). The collet holds the pin or stud to be welded. It is secured to the gun shaft by two set screws. These screws are loosened to remove or replace a collet. Tighten these screws snugly to secure the collet in place.

When you change the size of the stud you are welding, you must also change to the appropriate collet. If a collet becomes damaged or broken, it must be replaced. You may also need a stop.

11.3 GUN SET-UP FOR WELD PINS WITH COLLET PROTECTOR (see Figure 6)

The collet protector has several advantages over the standard set-up.

1. It does not require a pin stop. therefore, the same setup is applicable for a range of pin lengths.
2. There is a fixed plunge, no gun adjustments necessary.
3. It provides stability at the weld end of the pin.

There are two standard sizes available: 12 ga. And 10 ga. It is used with the round faceplate and three blunt legs. The collet protector slides over the collet and fastens to the chuck with three allen set screws. The insert, which takes the place of the Inter-teral stop, is replaceable.

The stud is pushed into the chuck until the flange bottoms out on the insert. The collet protector is not available for studs larger than 10 ga.

The standard adjustable legs and footpiece combination can alternately be used with the collet protector as shown in Figure 7.

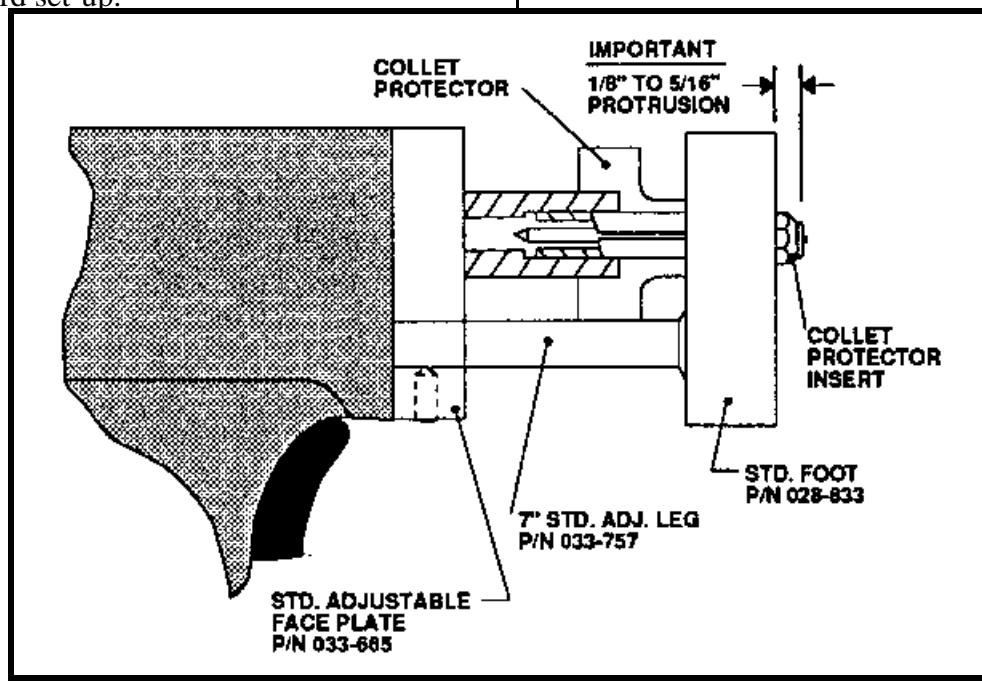

Figure 7 Collet Protector Gun Setup

11.4 TEMPLATE ADAPTER (see Figure 7)

The template adapter is used when precise location or positioning of the CD stud is required. It is used with the round faceplate and does not require a footpiece or legs. The adapter is fastened to the faceplate and provides a fixed distance between the collet and work. The plunge is set by using the correct stop in the collet. A template can then be fabricated to enable very precise locating of a particular stud.

The template adapter is available in two sizes, (1" and 1-1/4" diameter).

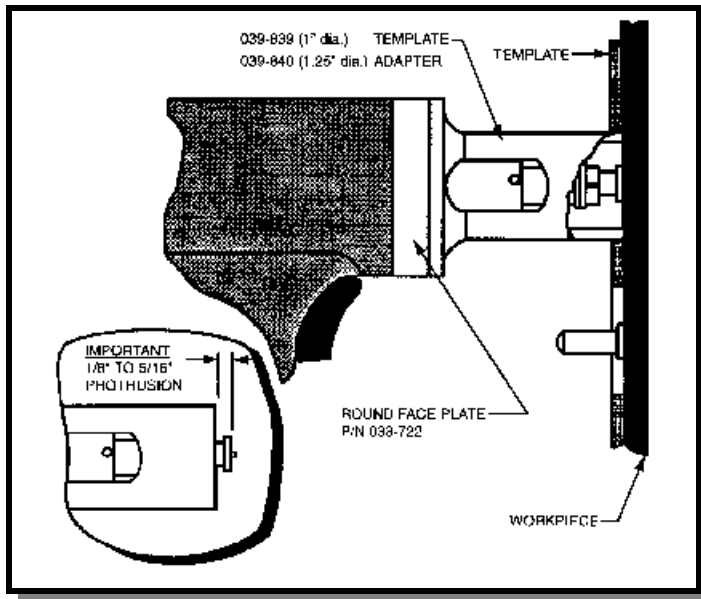

Figure 8 Template Adapter gun setup

11.5 COLLET PROTECTOR/BLUNT LEG
(see Figure 8)

The round faceplate, with blunt legs, can alternately be used with the collet protector as shown in Figure 8.

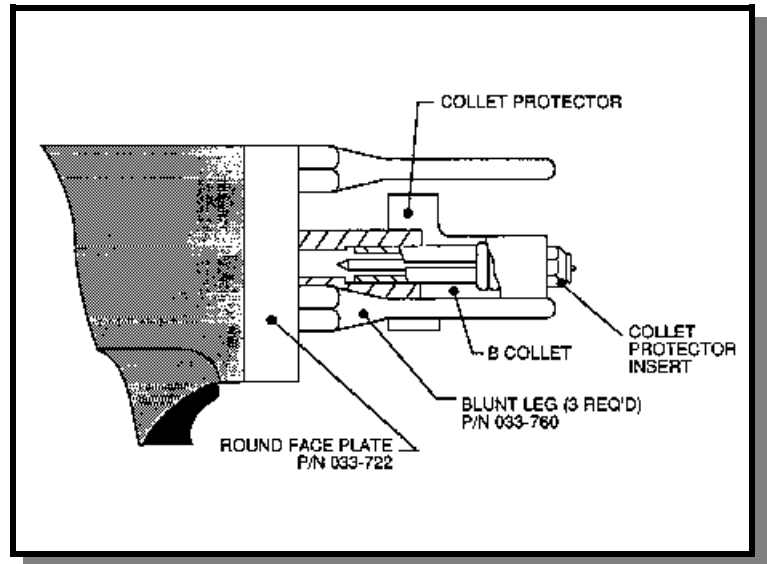

Figure 9 Collet Protector/Blunt Leg Setup

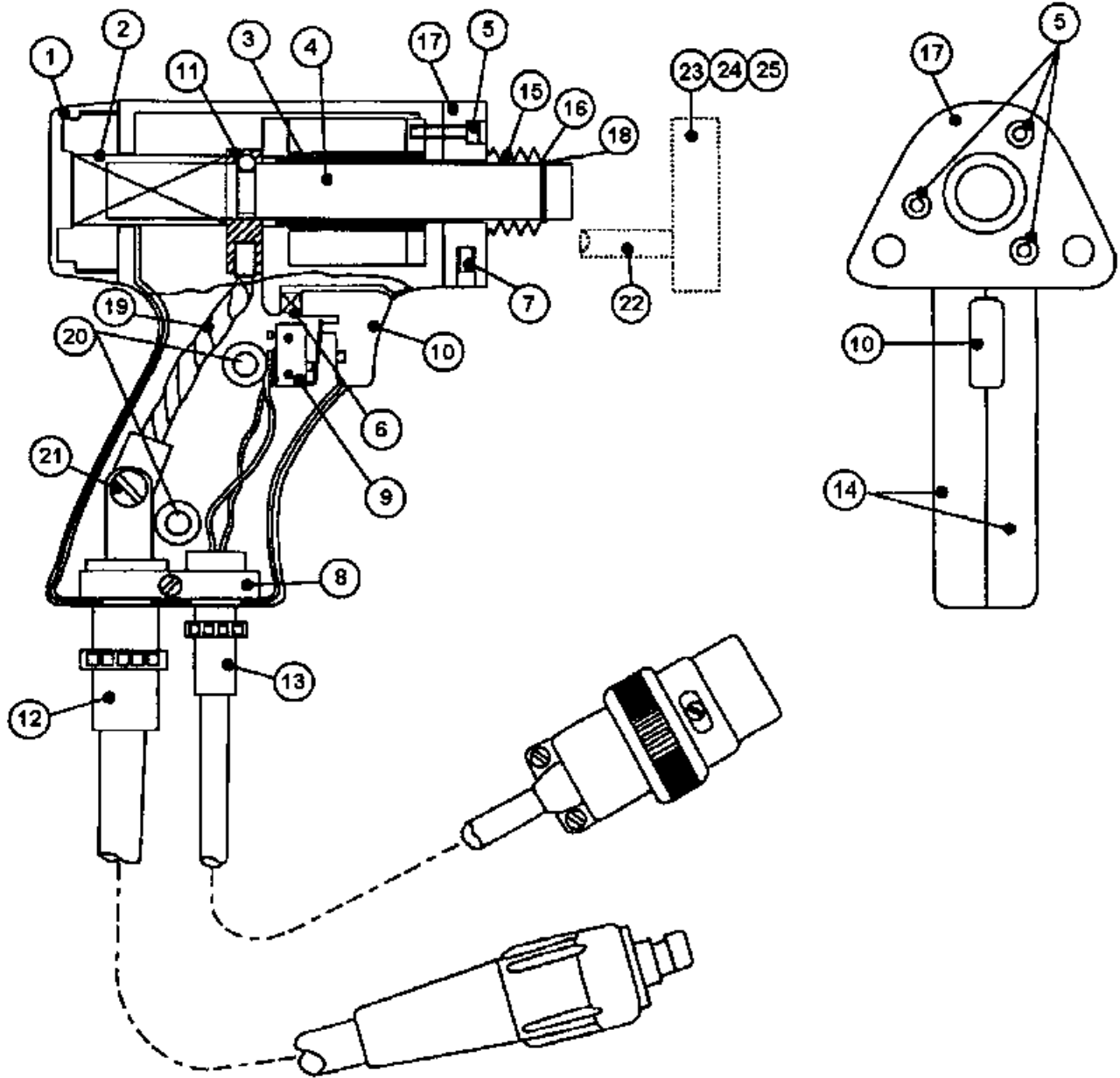

Figure 10 Light Duty CD Gun

11.6 PARTS LIST LIGHT DUTY CD HANDGUN

Part No. 300-0100

ITEM	PART NO.	DESCRIPTION	QTY
1	033-384	GUN (CD) REAR CAP MOLDED	1
2	001-800	SPRING MAIN HEAVY SILVER	1
3	033-610	GUN (CD/DA) BEARING ASSEMBLY	1
4	033-799	GUN (CD) SHAFT TUBE	1
5	033-016	HEX HEAD CAP SCREW	3
6	033-382	GUN (CD/DA/FA) TRIGGER SPRING	1
7	049-955	M SCREW SET MS, BRASS PLT	2
8	NOT USED	GUN (CD/DA/FA) CABLE CLAMP (ALUM. BLOCK)	1
9	033-404	TRIGGER SWITCH	1
10	033-381	GUN (CD/DA/FA) TRIGGER BUTTON MOLDED	1
11	036-496	GUN (FL) SHAFT BLOCK – A	1
12	033-662-25	GUN WELD CABLE (25 FT.)	1
13	033-658-25	GUN CONTROL CABLE (25 FT.)	1
14	033-881	GUN BODY RH & LH STD.CD MACHINED	1
15	033-445	GUN (CD/FL) SHAFT BOOT ASSY	1
16	033-447	GUN (CD) SHAFT BOOT RETAINING RING	1
17	033-665	GUN (CD) FACEPLATE – STD. ADJUSTABLE	1
18	033-446	GUN (CD) SHAFT BOOT SNAP RING	1
19	033-608	GUN (CD) WELD PIGTAIL ASSY	1
20	018-375	SCREW PAN HEAD	2
21	016-876	WASHED, LOCK INTO. TOOTH	1
22	033-757	LEG (CD) STD.ADJ. 7”	2 REF.
23	009-929	FLAT WASHER	2 REF.
24	016-378	SOCKET HEAD CAP SCREW	2 REF.
25	028-833	STD. FOOTPIECE	1 REF.

12.0 WELDABLE MATERIAL COMBINATIONS

BASE MATERIAL	STUD MATERIALS
Mild Steel (1008-1018)	Mild Steel 1008, 1018 Stainless Steel 304, 305 Brass 65-35, 70-30 Copper, Silicon/Bronze
Galvanized Sheet (duct-”Q” Decking)	Mild Steel 1008-1018 Stainless Steel 304,305
Structural Steel (Must Be Clean)	Mild Steel 1008,1018 Stainless Steel 304,305 Brass 65-35, 70-30
Aluminum – Most alloys of the 1100, 3000 and 5000 series.	Aluminum 1100,5356
Zinc Alloys (Die Cast)	Aluminum 1100, 5356
Medium Carbon Steel (1030-1018)	Mild Steel 1008, 1018 Stainless Steel 304,305 Brass 65-35, 70-30
Lead Free Brass Lead Free Rolled Brass Electrolytic Copper	Mild Steel 1008, 1018 Stainless Steel 304, 305 Copper, Silicon/Bronze

13.0 CAUSE OF POOR OR ERRATIC WELDS

1. Loose collet. Does not grip stud tightly. (REPLACE) Not enough engagement of stud to collet. (CHANGE STOP)
2. Fault or loose ground connection. (REPAIR OR TIGHTEN)
3. Poor surface condition of base material, excessive oil, grease, rust, ect. (CLEAN)
4. Voltage or capacitance setting too low or too high. (ADJUST TO DIAMETER OF STUD)
5. Broken or loose cables. (REPAIR)
6. Dirt in gun. (CLEAN)
7. Incorrect polarity. (CABLES HOOKED-UP WRONG)
8. Use of center punch or deep scribe. (DO NOT USE CENTER PUNCH OR DEEP SCRIBES)
9. Cables too closely coiled.
10. Arc blow is evidenced by “one side” welds. In severe cases there will be no melting under one edge of flange while the opposite side is gouged out or appears excessively hot. The principle cause of arc blow is magnetic field induced by the current flow during the weld. It occurs most often on long, narrow strips of metal or near edges of sheets or plates. In some cases, a change in grounding positions, or two grounds on the work piece, one at each end or edge of work, will correct the problem. For assistance in severe cases, contact your local sales representative.
11. Incorrect plunge setting. (ADJUST TO PROPER SETTING)

12. Incorrect spring. (REPLACE WITH PROPER SPRING)

13. Poor stud quality.

14.0 TROUBLE SHOOTING POOR WELDS

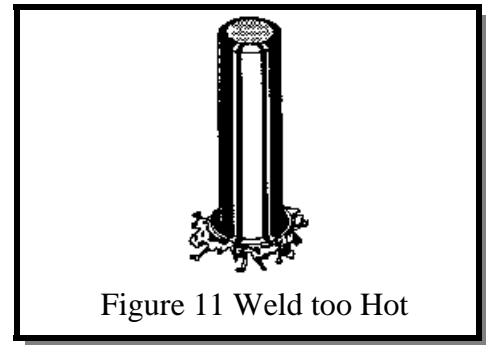

Weld too Hot

- A) Decrease voltage.
- B) Decrease capacitance.
- C) Increase stud protrusion.
- D) Increase spring pressure.

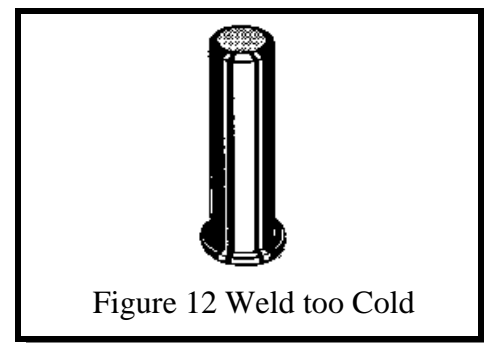

Weld too Cold

- A) Increase voltage.
- B) Increase capacitance.
- C) Decrease stud protrusion.
- D) Decrease spring pressure.

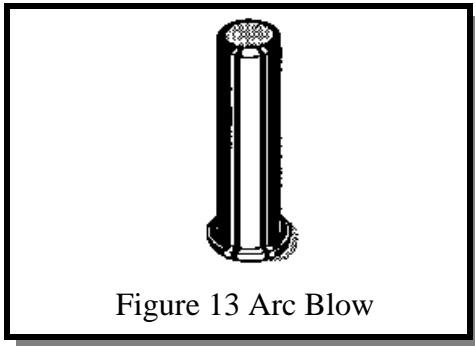

Figure 13 Arc Blow

Arc Blow

- A) Use double grounds.
- B) Ground too close or not spaced

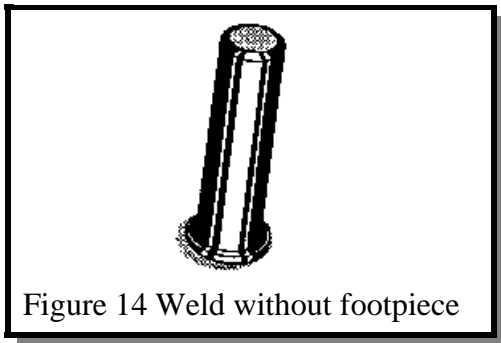

Figure 14 Weld without footpiece

Weld without footpiece

- A) Use standard footpiece.
- B) Use template adapter.
- C) Use tripod blunt legs.

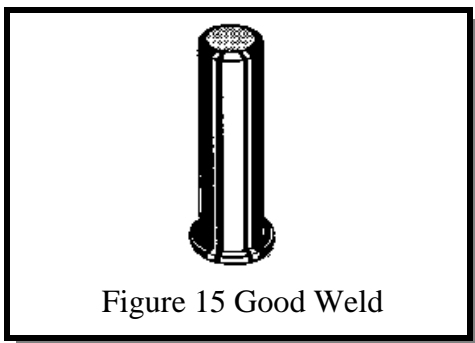

Figure 15 Good Weld

15.0 ROUTINE WELDER MAINTENANCE

Your CD-312 is designed for long service with minimum care. Ordinary common sense maintenance will keep it operating efficiently.

1. Treat the welding, ground, and control cables with respect. Avoid sharp bends and kinks which may break the cables. Don't use the cables as a "tow line" to move the control. Avoid damage or straining the cables where they enter the gun or at the connectors.

2. It is good practice to occasionally remove the cover of the controller and clean with air and a soft brush around the components.

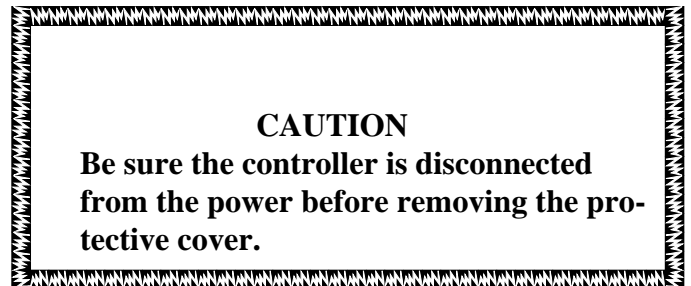

3. While the cover is removed, tighten all the weld cable connections and make sure all the screws on the capacitor terminals are torque to 30 inch-pounds.

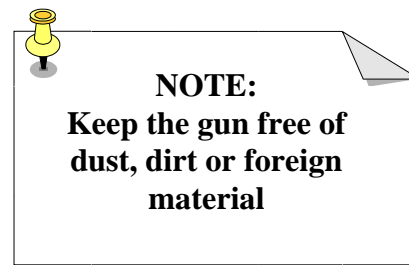

16.0 ASSEMBLY CD-312 CONTROLLER (see Figure 15,16, & 17)

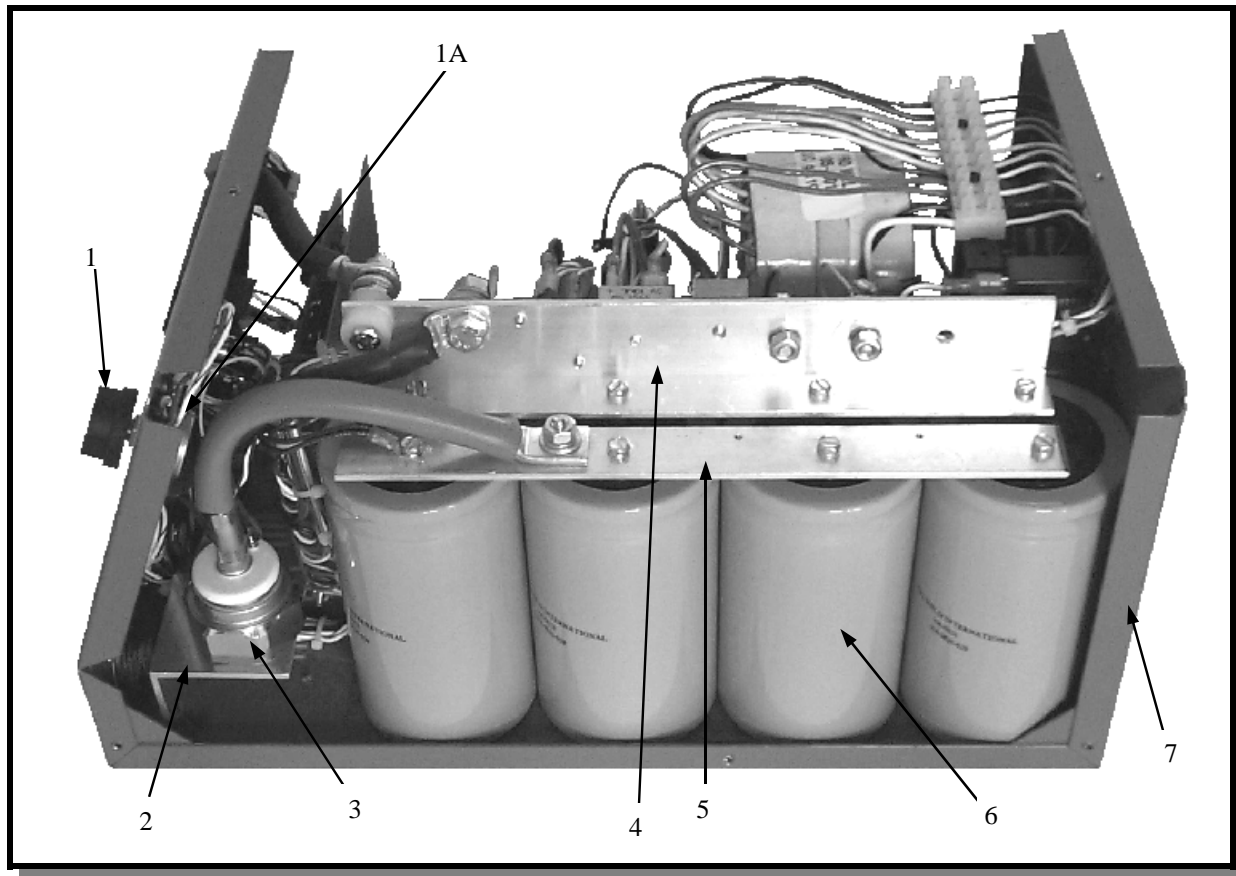

Figure 16 Parts List

ITEM	DESCRIPTION	PART NUMBER
1	Knob	102-0060
1A	Charge Pot 25K	111-0001
2	SCR Mounting	124-0026
3	Main SCR	108-0001
4	Buss Bar	124-0037
5	Buss Bar	124-0036
6	Capacitor	106-0023
7	Chassis	101-0016

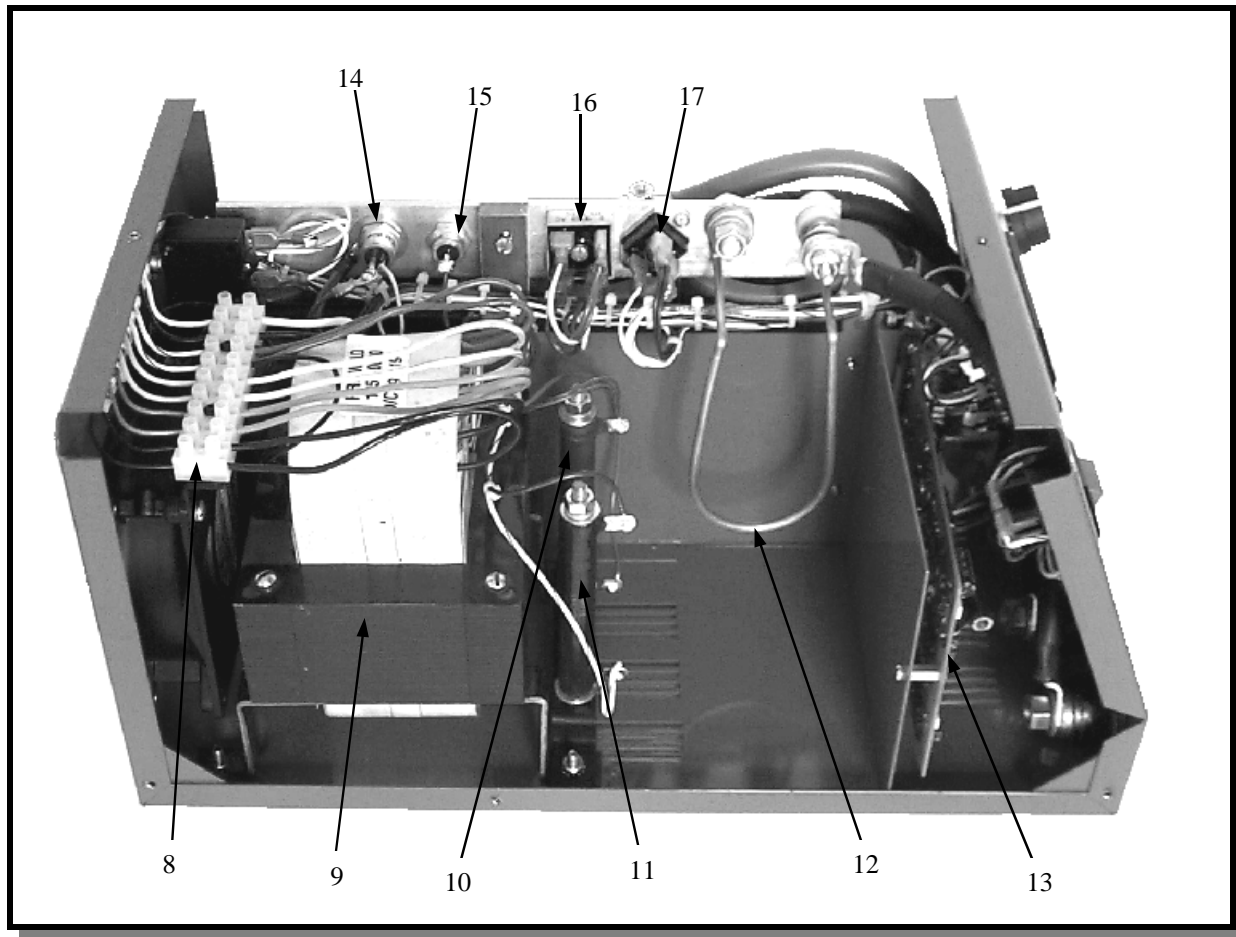

Figure 17 Parts List

ITEM	DESCRIPTION	PART NUMBER
8	Terminal Strip	102-0020
9	Transformer	105-0010
10	Dropping Resistor	112-0042
11	Discharge Resistor	112-0041
12	Nichrome Resistor	112-0043
13	PC Board	600-0007
14	Charging SCR	108-0002
15	Diode	108-0027
16	Charging Bridge	108-0017
17	Safety Discharge SCR	108-0042

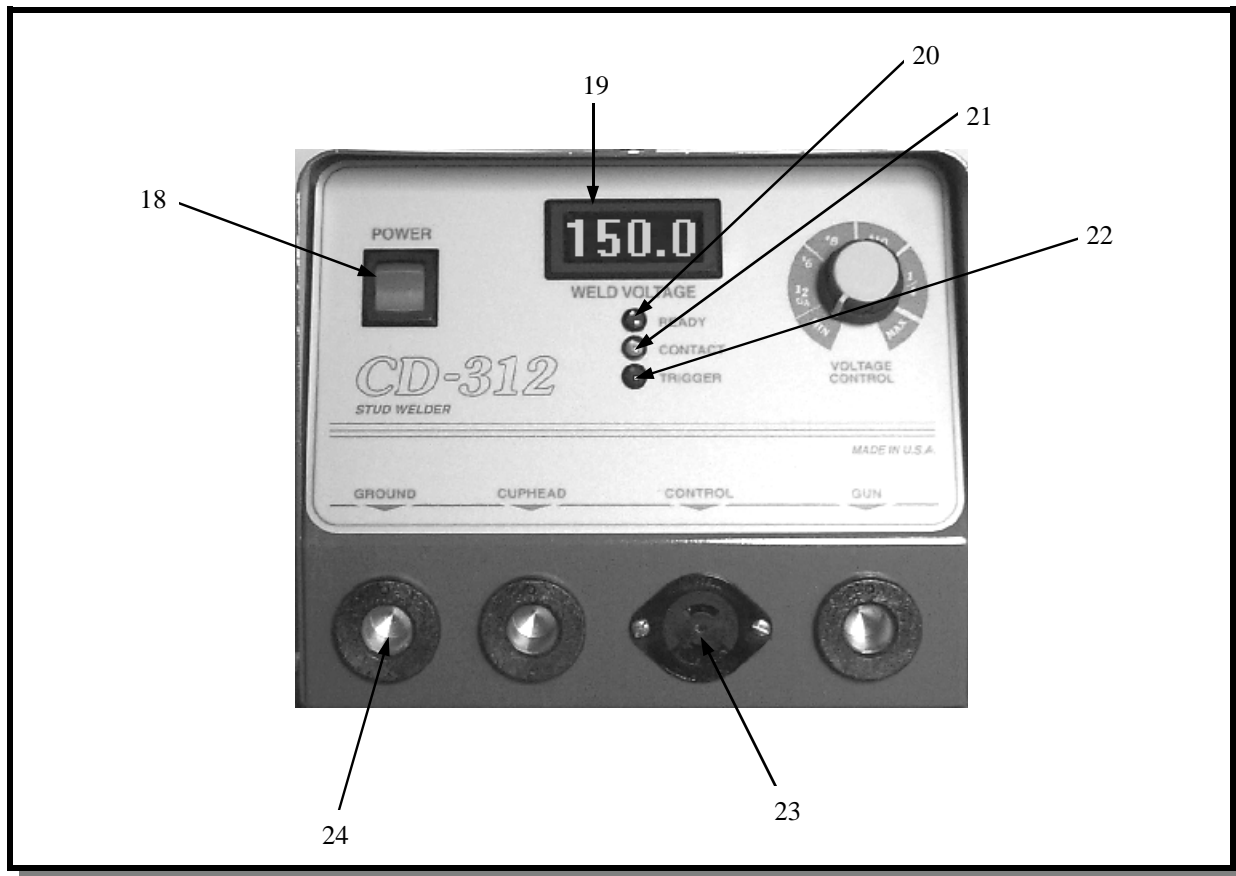

Figure 18 Parts List

ITEM	DESCRIPTION	PART NUMBER
18	Power Switch	104-0013
19	LED Panel Meter	103-0002
20	LED Red	108-0028
21	LED Green	108-0029
22	LED Amber	108-0030
23	2-Pole Female Hubbell	107-0031
24	Female Camlok	107-0002

16.1 PC BOARD ASSEMBLY DRAWING
FU2 and FU3 are 3AG 1 ampere fuses

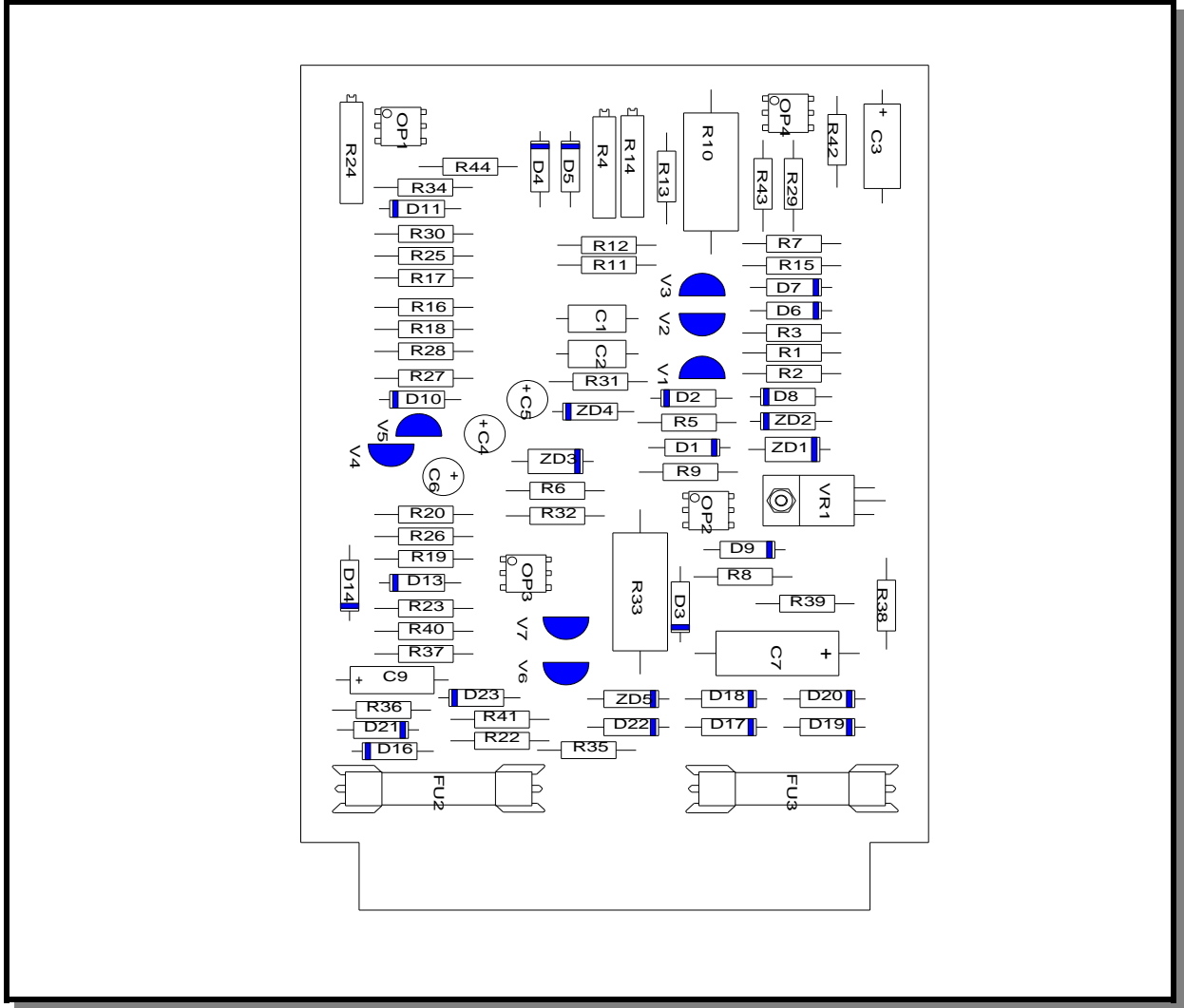

Figure 19 PC Board

17.0 TROUBLE SHOOTING – ELECTRICAL

When troubleshooting the power unit/controller (welder), the following precautions must be observed:

1. Welder must be **TURNED OFF!**
2. Unplug power cable from welder and wait at least two minutes before checking components.
3. The use of a volt/ohmmeter is recommended where any voltage may be present.
4. Use a continuity tester (or troubleshooting light) for continuity checks only.
5. Possible causes marked with a star (*) are generally the most common problems.

PROBLEM	POSSIBLE CAUSE	CORRECTIVE ACTION
1. Welder does not turn on and will not weld.	A. Power connections at Welder or 110 VAC outlet not complete.	Check connections.
	*B. Broken power cable or loose wire connection in the plug.	Check wires for continuity. Repair break.
	C. Fuse blown.	Replace fuse.
2. Fuse blows each time unit is turned on.	*A. Shorted weld capacitor.	Check safety vent seal for Rupture hole. Replace defective capacitor.
	B. Shorted rectifier (BR1)	Check for a short across the rectifier with ohmmeter. Replace rectifier module if shorted.
	C. Incorrect primary hookup.	Check transformer connections.
	D. Shorted transformer assembly.	Replace transformer.

PROBLEM	POSSIBLE CAUSE	CORRECTIVE ACTION
3. Welder turns on but does not operate	A. Ground cable connections not complete.	Check for continuity
	*B. Broken gun control cable or loose wire connection in the plug. Shorted or open trigger switch.	Check continuity between pins on control plug while trigger is depressed. Should read continuity.
	*C. Faulty printed circuit board.	Replace with new PC Board.
	D. Shorted weld SCR.	Check with ohmmeter (should not show continuity in either direction). Replace rectifier module if shorted.
4. Weld is excessively hot regardless of voltage setting.	A. Shorted charge SCR.	Check with ohmmeter (should not show continuity In either direction). Replace if shorted.
	*B. Faulty printed circuit board.	Replace with new PC Board.
	C. Open voltage potentiometer.	Replace defective voltage Potentiometer.
5. Poor and erratic welding.	A. Improper gun setup.	Check applicable gun setup Instruction page.
	B. Improper grounding or cable setup or incorrect polarity.	Check applicable cable setup Instruction page.
	C. Weld cables are coiled.	Straighten out cables.
	D. Incorrect voltage setting.	Adjust as necessary.
	E. Studs or pins not perpendicular to work surface.	Adjust legs as necessary. Replace defective legs.

18.0 CHECK LIST CD-312 SYSTEM PT. NO. 100-0108

STANDARD CD-312 WELDING SYSTEM COMPLETE WITH B-COLLET GUN
AND 25' #4 GROUND CABLE

ITEM	DESCRIPTION	PART #	QTY
1.	CD-312 CONTROLLER 110 VAC	200-0012	1
2.	GUN ASSY. B-COLLET w/INTEGRAL 25 FT.WELD & CONTROL CABLE 2-LEGS, and FOOTPIECE	300-0100	1
3.	GROUND CABLE #4 X 15'	125-0100	1
4.	MANUAL, Operation and Maintenance CD-312		1
5.	HEX WRENCH SET		1

19.0 CHECK LIST CD-312 SYSTEM PT. NO. 100-0109

STANDARD CD-312 WELDING SYSTEM COMPLETE WITH TAPER TIP GUN
AND 25' #4 GROUND CABLE

ITEM	DESCRIPTION	PART #	QTY
1.	CD-312 CONTROLLER 110 VAC	200-0012	1
2.	GUN ASSY. TAPER TIP w/INTEGRAL 25 FT.WELD & CONTROL CABLE 2-LEGS, and FOOTPIECE	300-0101	1
3.	GROUND CABLE #4 X 15'	125-0100	1
4.	MANUAL, Operation and Maintenance CD-312		1
5.	HEX WRENCH SET		1



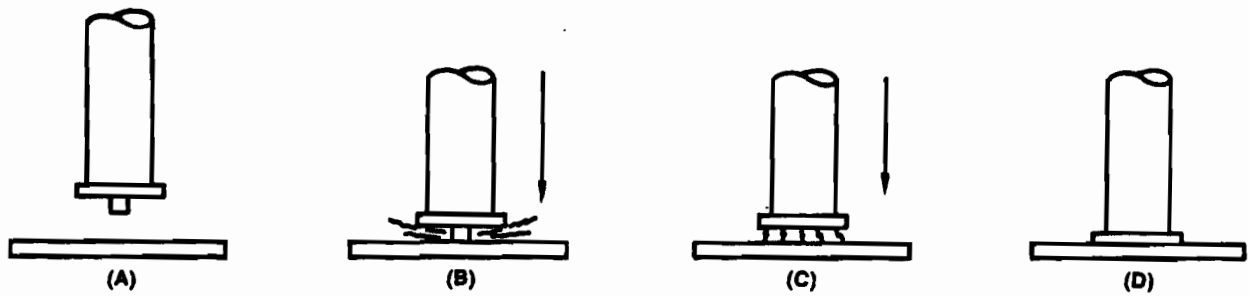

Figure 3 — Steps in Contact Capacitor Discharge Stud Welding

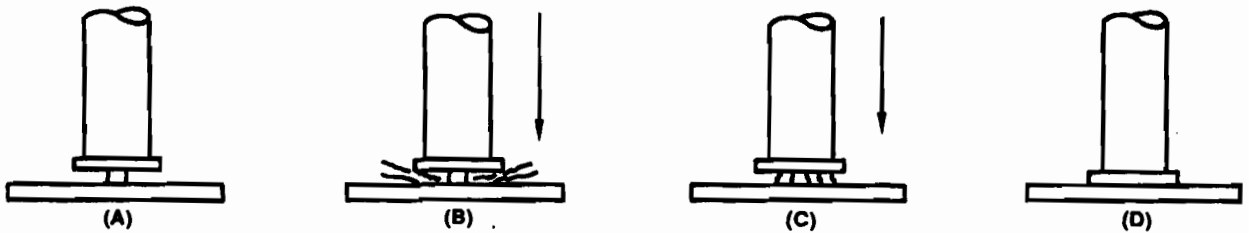

Figure 4 — Steps in Gap Capacitor Discharge Stud Welding

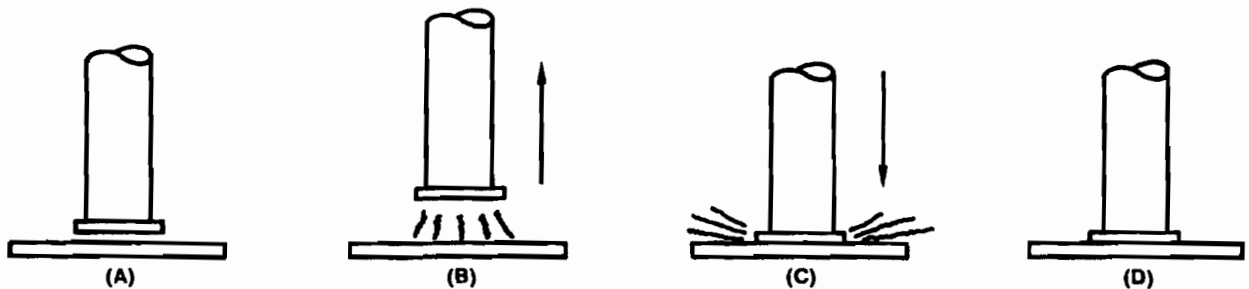

Figure 5 — Steps in Drawn-Arc Capacitor Discharge Stud Welding

surface. The spring action of the welding gun plunges the stud into the molten metal to complete the weld, Figure 5(C). The completed weld is shown in Figure 5(D).

A short welding time, 3 to 6 milliseconds (ms) for the gap and contact methods and 6 to 12 ms for the drawn-arc method, prevents heat buildup in the workpiece. This permits welding of studs to thin metal sections without discoloration or melt-through. Depending upon the section thickness, a paint or vinyl coating on the other side of the welded surface is not damaged. The shallow penetration permits many dissimilar metals to be welded with acceptable strengths and metallurgical characteristics.

2. Selection of Method

There are some applications for which the capabilities of arc stud welding and capacitor discharge stud welding overlap, but generally the selection between these two basic methods is well defined. A selection chart is shown in Table 1. The area in which selection is usually more difficult is the choice of the capacitor discharge method to use, i.e., contact, gap, or drawn-arc.

The main criteria for selecting the stud welding method are fastener size, base metal thickness, and base metal composition. Using these criteria, it is almost always possible to select the best method.